

# dormakaba DK 120

## Automatic sliding door operator

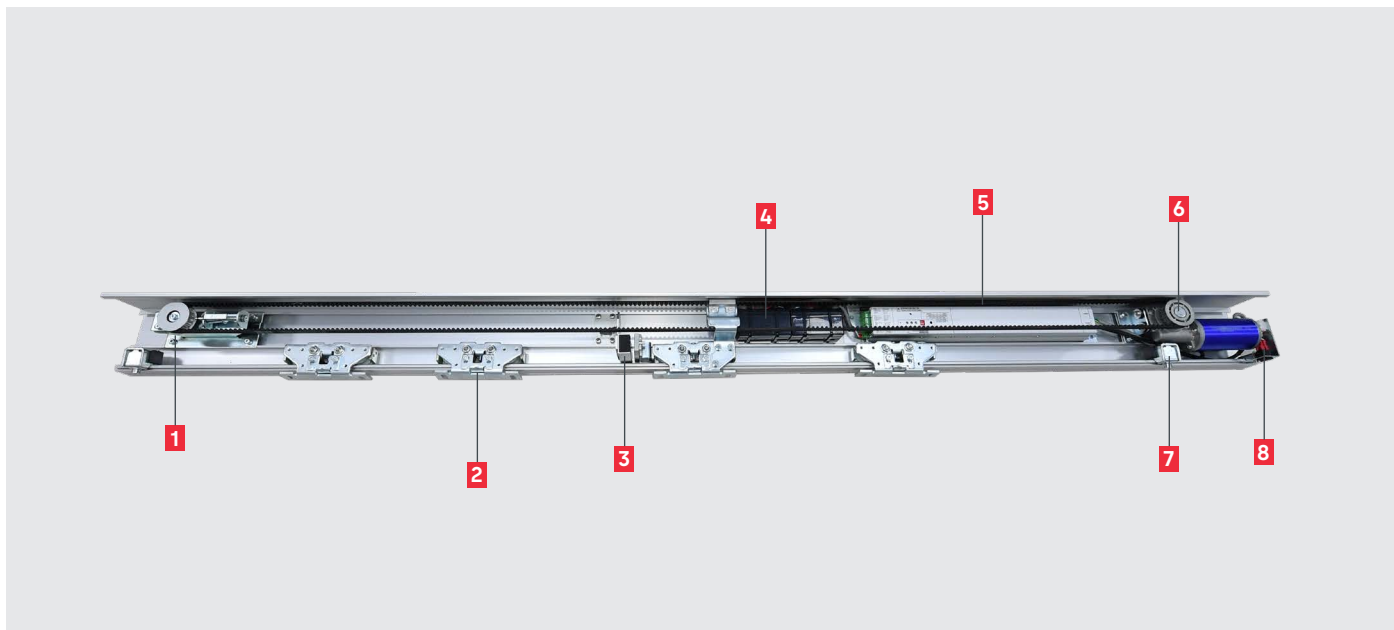

## Features

The DK 120 automatic sliding door drive features a new controller and high torque motor that can accommodate a load of 2x120 kg for wider entrances.

- High torque brushless DC motor to drive larger doors
- Self-adjusting nylon wheels for smoother and quieter operation
- Heavy-duty
- Optimised controller providing enhanced safety
- Synchronisable with 2 operators for applications up to 2 x 120 kg
- Built-in back-up battery (optional) which provides emergency operations in the event of a power failure

## Components

- 1** Return pulley with integrated tensioner
- 2** Hanger bracket
- 3** Magnetic lock (optional)
- 4** Backup battery (optional)
- 5** Control unit
- 6** Drive motor
- 7** End stopper
- 8** Main power switch

## Dimensions

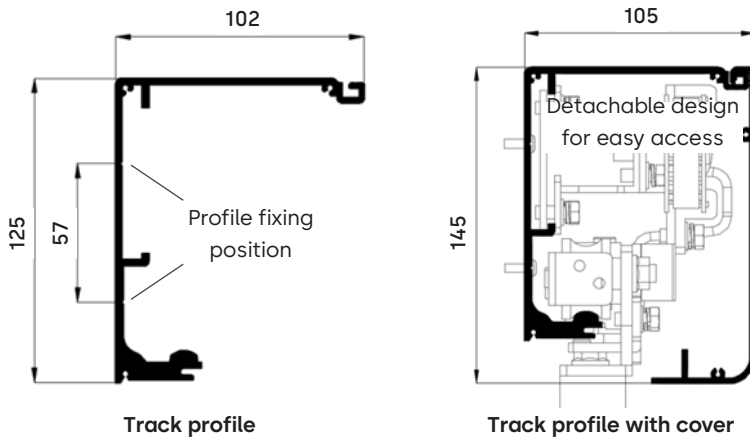

## Connections

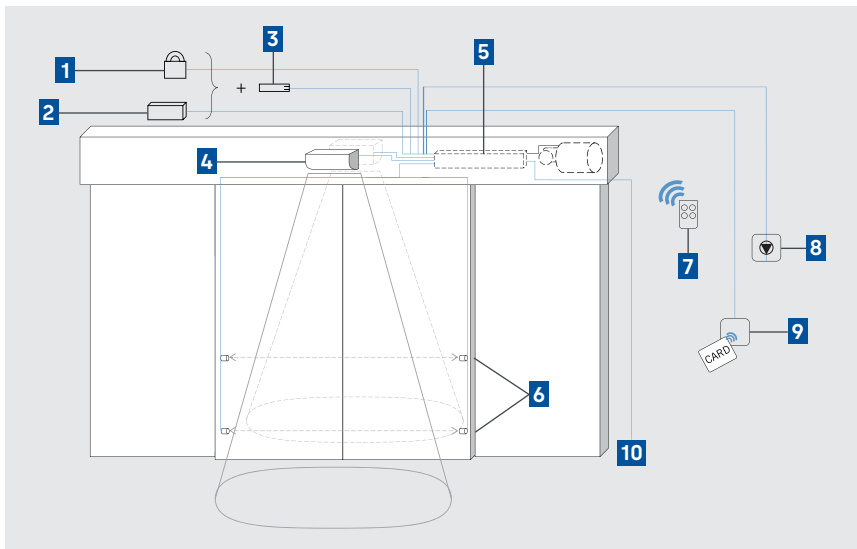

- |                                    |   |
|------------------------------------|---|
| <b>1</b> Magnetic lock (optional)  | <b>7</b> Wireless remote (optional)                 |
| <b>2</b> Backup battery (optional) | <b>8</b> Program switch                             |
| <b>3</b> Upgrade module (optional) | <b>9</b> Card reader<br>(access control activation) |
| <b>4</b> Radar motion detector     | <b>10</b> Power supply<br>110/230 V<br>50/60 Hz     |
| <b>5</b> Control unit              |   |
| <b>6</b> Safety light barrier      |   |

## Accessories

### Door Activator

Microwave motion detection sensor

- Detection range: 4m×2m×3m (width×depth×height)
- Sensitivity: minimum 5cm/s motion detection
- Temperature range: -20°C ~ 50°C
- Protection rating: IP52

### Safety sensor (optional)

Light barrier sensors for the protection of passage way using active infrared technology.

- Detection range: max width: up to 5 m  
min height: 0.2 m\*
- Temperature range: -20 °C ~ 60 °C
- Protection rating: IP65

\*When the protective distance exceeds 1.5m, installation height is recommended to be not less than 0.3 m.

### Wireless remote (optional)

- 32-bit encryption for added security
- 15 m long range, 4 channel remote control
- Simple design, compact size, portable

### 3-position program switch (optional)

- Clean and durable aluminum alloy panel
- Wall mounting for easy operation

## Factsheet

# Technical specifications

## DK 120 automatic sliding door operator

<b>Door parameters</b>	Single panel	Clear opening width Door panel weight	700 - 1200 mm Max. 130 kg
	Double panel	Clear opening width Door panel weight	700 - 2400 mm Max. 2 x 120 kg
<b>Technical parameters</b>	Height		125 mm
	Depth		102mm
	Length		2 x 2.5 m
	Manual push open force (without power)		150 N
	Opening speed		10 - 42 cm/s
	Closing speed		10 - 40 cm/s
	Hold open time		1 - 11 seconds
	Power supply		230V 50/60 Hz
	Max power		150 W
	Protection		IP 20
	Temperature		-20 °C - 50 °C
<b>Optional accessories</b>	Built-in magnetic lock	<input type="radio"/>	
	Backup battery	<input type="radio"/>	
	3 position mode switch	<input type="radio"/>	
<b>Control module</b>	Microprocessor controller		
	Wireless remote control	<input type="radio"/>	Lock/close
		<input type="radio"/>	Automatic
		<input type="radio"/>	Exit
		<input type="radio"/>	Permanently open
	Self-learning function	<input checked="" type="radio"/>	
	Opens automatically in case of obstruction	<input checked="" type="radio"/>	
	3 position mode switch	<input type="radio"/>	
	Security open for access control	<input checked="" type="radio"/>	
	Safety input	<input type="radio"/>	
Backup mode (with battery)	<input type="radio"/>	Uninterrupted operation	
	<input type="radio"/>	Emergency opening	
	<input type="radio"/>	Emergency closing	

● Yes    ○ Optional

Any questions?

We would be happy to advise you.

Email us at [info.asean@dormakaba.com](mailto:info.asean@dormakaba.com)

<b>dormakaba Singapore Pte Ltd</b> Tel   +65 6268 7633	12 Tukang Innovation Drive #04-01 Singapore 618303
<b>dormakaba Malaysia Sdn Bhd</b> Tel   +603 8081 8009	No. 3 Jalan TP 6 Taman Perindustrian UEP 47600 Subang Jaya, Selangor Darul Ehsan, Malaysia
<b>PT. dormakaba Access Indonesia</b> Tel   +62 21 2930 3762	Jl. Ciputat Raya No. 335, RT. 002 RW. 007 Kebayoran Lama Utara, Kebayoran Lama Kota Adm 12240 Jakarta Selatan, Indonesia
<b>dormakaba Philippines Inc.</b> Tel   +632 8893 4077	Unit 102 RCI Building, 105 Rada St., Legaspi Village 1229 Makati City, Philippines
<b>dormakaba (Thailand) Limited</b> Tel   +66 2059 2612	762/2 Room no. A258, Rama 3 Road Bangpongpan, Yannawa, 10120 Bangkok, Thailand
<b>dormakaba Tokyo</b> Tel   +81 3 6327 2010	2-16-1 Minamikamata, Ota-Ku, Tokyo, Japan 144-0035
<b>dormakaba Osaka</b> Tel   +81 6 4790 7560	2F Shimamachi daini Nomura Bldg. 2-4-9 Shimamachi, Chuo-ku, Osaka, Japan 540-0034
<b>dormakaba Korea Inc.</b> Tel   +82 2 6956 4382	Sungmoon Building 201 2636, Nambusunhwan-ro, Seocho-gu, Seoul, Korea 06738
<b>dormakaba Vietnam Rep Office</b> Tel   +84 8 6299 8272	Centec Business Center, Unit 002, Floor 4, 72-74 Nguyen Thi Minh Khai Street, Vo Thi Sau Ward 722700 District 3, Ho Chi Minh City, Vietnam